

1) WARNING:



- USE COVER BOLTS CLASS A4-70
- DO NOT OPEN WHEN AN EXPLOSIVE ATMOSPHERE IS PRESENT
- POTENTIAL ELECTROSTATIC HAZARD
- FOR INDOOR OR OUTDOOR USE
- TO REDUCE THE RISK OF IGNITION OF HAZARDOUS ATMOSPHERES, CONDUIT RUNS MUST HAVE A SEALING FITTING CONNECTED WITHIN 18 INCHES OF CONDUIT
- CAUTION - RISK OF ELECTRIC SHOCK - MORE THAN ONE DISCONNECT MAY BE REQUIRED TO DE-ENERGIZE THE EQUIPMENT BEFORE SERVICING

AVERTISSEMENT:

- UTILISER COUVRIR BOULONS CLASSE A4-70
- NE PAS OUVRIR UN PRESENCE D'ATMOSPHERE EXPLOSIVE
- DANGER POTENTIEL CHARGE ÉLECTROSTATIQUE - VOIR LES INSTRUCTIONS
- POUR USAGE INTÉRIEUR OU EXTERIEUR
- POUR RÉDUIRE LE RISQUE D'INFLAMMATION DES ATMOSPHÈRES DANGEREUSES, LES CONDUITES DE CONDUIT DOIVENT AVOIR UN RACCORD D'ÉTANCHÉITÉ RACCORDÉ À MOINS DE 18 POUCHES DE L'ENFERMEMENT
- ATTENTION - RISQUE DE CHOC ELECTRIQUE - PLUSIEURS SECTIONNEURS PEUVENT ETRE NECESSAIRES POUR COUPER L'ALIMENTATION DE L'APPAREILLAGE AVANT D'ENTREPRENDRE L'ENTRETIEN

2) Rating & Marking Information

2.1 NEC & CEC Class / Division Ratings for US / Canada

The GNExCP7 callpoints comply with the following standards:

UL 60947-4-1 Low voltage switchgear and controlgear – Part 4-1: Contactors and motorstarters – Electromechanical contactors and motorstarters – Ed. 3 Rev. date 2017/10/

CSA C22.2 NO. 60947-4-1-14 Low voltage switchgear and controlgear – Part 4-1: Contactors and motorstarters – Electromechanical contactors and motorstarters – Ed. 2 - Issue Date 2014/01/04

The GNExCP7 callpoints are rated as follows:

Class I Div 2 Group ABCD T6 Ta -55°C to +60°C
Class II Div 2 Group FG T4 Ta -55°C to +60°C
Class III Div 1 & 2 Ta -55°C to +60°C

2.2 NEC Class / Zone ratings US

The GNExCP7 callpoints comply with the following standards:

UL 60079-0:2017 (Ed 6): Explosive Atmospheres - Part 0: Equipment - General requirements
UL 60079-1:2015 (Ed7): Explosive Atmospheres - Part 1: Equipment protection by flameproof enclosures "d"
UL 60079-31:2012 (Ed 2): Explosive Atmospheres - Part 31: Equipment dust ignition protection by enclosure "t"

The GNExCP7 callpoints are rated as follows:

Class I Zone 1 AEx db IIC T6 Gb (Ta -55°C to +60°C)
Zone 21 AEx tb IIIC T125°C Db (Ta -55°C to +60°C)

2.3 CEC Class / Zone ratings Canada

The GNExCP7 callpoints comply with the following standards:

CSA C22.2 NO. 60079-0:2015 (Ed 3) Explosive Atmospheres – Part 0: Equipment – General requirements
CSA C22.2 NO. 60079-1:2016 (Ed 3): Explosive Atmospheres – Part 1: Equipment protection by flameproof enclosures "d"
CSA C22.2 NO. 60079-31:2015 (Ed 2): Explosive Atmospheres – Part 31: Equipment dust ignition protection by enclosure "t"

The GNExCP7 callpoints are rated as follows:

Class I Zone 1 Ex db IIC T6 Gb X (Ta -55°C to +60°C)
Zone 21 Ex tb IIIC T125°C Db (Ta -55°C to +60°C)

2.4 ATEX / IECEx Certification

The GNExCP7 callpoints comply with the following standards:

EN60079-0:2018 / IEC60079-0:2017 (Ed 7): Explosive Atmospheres – Part 0: Equipment. General requirements
EN60079-1:2014 / IEC60079-1:2014 (Ed 7): Explosive Atmospheres - Part 1: Equipment protection by flameproof enclosures "d"
EN 60079-31:2014 / IEC 60079-31:2013 (Ed 2): Explosive Atmospheres - Part 31: Equipment dust ignition protection by enclosure "t"

All units have a rating label, which carries the following important information: -

Model No.: GNExCP7-PB-S (Single Switch)
GNExCP7-PB-D (Dual Switch)

GNExCP7-PM-S (Single Switch)
GNExCP7-PM-D (Dual Switch)

GNExCP7-PT-S (Single Switch)
GNExCP7-PT-D (Dual Switch)

Input Voltage: 24Vdc max / 3.0A max
48Vdc max / 1.0A max
250Vac max / 5.0A max (units without series or end-of-line devices only)

Ex db IIC T5 Gb Ta. -55 to +70°C
Ex db IIC T6 Gb Ta. -55 to +60°C
Ex tb IIIC T90°C Db Ta. -55° to +70°C

Certificate No. DEMKO 19 ATEX 2101X
IECEX ULD 19.0007X

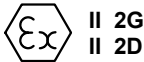
ATEX Marking Equipment Group and Category:  II 2G
II 2D

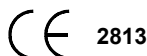
CE Marking Notified Body No.  2813

The units can be installed in locations with the following conditions:

Area Classification Gas:

Zone 1	Explosive gas air mixture likely to occur in normal operation.
Zone 2	Explosive gas atmosphere not likely to occur in normal operation but may be present for short periods.

Gas Groupings:

Group IIA	Propane
Group IIB	Ethylene
Group IIC	Hydrogen and Acetylene

Temperature Classification:

T1	450°C
T2	300°C
T3	200°C
T4	135°C
T5	100°C
T6	85°C (only up to Tamb 60°C)

Area Classification Dust:

Zone 21	Explosive dust air mixture likely to occur in normal operation.
Zone 22	Explosive dust air mixture not likely to occur in normal operation, and if it does, it will only exist for a short time.

Dust Groupings:

Group IIIA	Combustible Flyings
Group IIIB	Non-conductive Dust
Group IIIC	Conductive Dust

Maximum Surface Temperature for Dust Applications:

ATEX/IECEX: 90°C
NEC/CEC: 125°C

IP Rating: IP66/67 to EN/IEC60529 and IP6X to EN/IEC60079-0, EN/IEC60079-31

Equipment Category: 2G / 2D

Equipment Protection Level: Gb, Gc, Db, Dc

Ambient Temperature Range:
ATEX/IECEX: 55°C to +70°C
NEC/CEC: 55°C to +60°C

Pollution Degree: 3

3) Installation Requirements

The unit must only be installed by suitably qualified personnel in accordance with the latest issues of the relevant standards:

EN60079-14 / IEC60079-14: Explosive atmospheres - Electrical installations design, selection and erection

EN60079-10-1 / IEC60079-10-1: Explosive atmospheres - Classification of areas. Explosive gas atmospheres

The installation of the units must also be in accordance with any local codes that may apply and should only be carried out by a competent electrical engineer who has the necessary training.

The equipment must not be installed with any obstruction to the flanged flameproof joint any closer than permitted as per EN/IEC60079-14, table 13.

4) Special Conditions of Use

The stainless steel button is not earthed and may generate an ignition-capable level of electrostatic charges. It has a max capacitance of 6.33pF according to EN/IEC60079-0, clause 7.5.

Equipment is permitted to be wall mounted only in vertical position. The enclosure base is permitted in two mounting positions, with the double entry lowermost or uppermost.

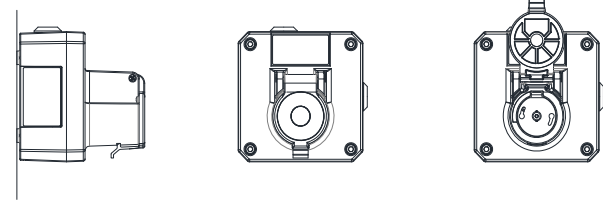

No repair to the Flamepaths is permitted

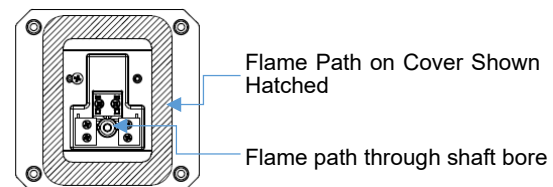
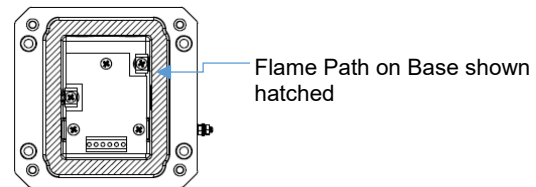

5) Location and Mounting

The location of the call point should enable ease of access for operation and testing. The unit should be mounted using the 4 off fixing holes which will accept up to M5 sized fixings. They should only be fixed to services that can carry the weight of the unit.

To gain access to the mounting holes in the base the front cover must be removed. See Section 7.

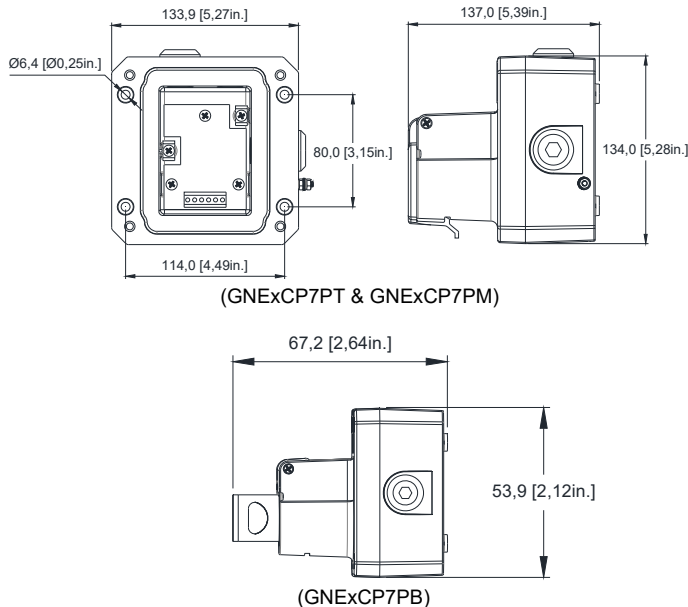

Fig. 1 View of base unit showing fixing centres (in mm).

6) Access to the Flameproof Enclosure



Warning – High voltage may be present, risk of electric shock. DO NOT open when energised, disconnect power before opening.



Warning – Hot surfaces. External surfaces and internal components may be hot after operation, take care when handling the equipment.

To access the Ex d chamber, remove the four off M6 x 50 hexagon socket head screws and withdraw the flameproof cover taking extreme care not to damage the flameproof joints in the process. M6 cover screws are Class A4-70 stainless steel and only screws of this category can be used for the enclosure.

On completion of the installation, the flameproof joints should be inspected to ensure that they are clean and that they have not been damaged during installation.

Once the screws are removed the cover will hang down out of the way to gain access to the terminals, the internal earth terminal and mounting hole recesses.

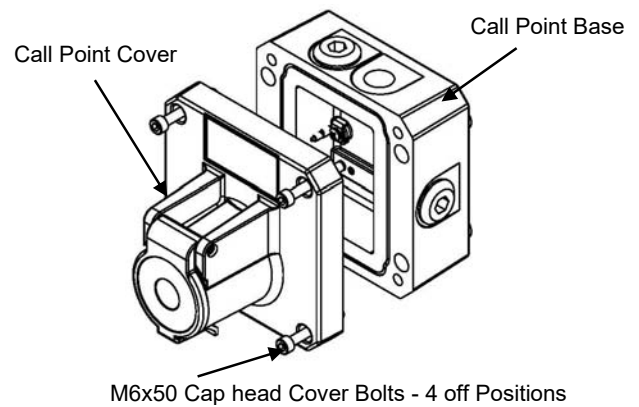

Fig. 2 Accessing the Explosion proof Enclosure.

Check that the earth bonding wire between the two castings is secure and the 'O' ring seal is in place.

When fitting the flameproof cover ensure the cover is sitting flat and correctly positioned on the base. Insert the M6 x 50 stainless steel A4-70 Cap Head cover bolts and fully tighten down (tightening torque 3.5Nm), ensuring no gap is visible between the cover and base of the enclosure.

The enclosure is non-conductive and may generate an ignition-capable level of electrostatic charges under certain extreme conditions. The user should ensure that the equipment is not installed in a location where it may be subjected to external conditions that might cause a build-up of electrostatic charges on non-conducting surfaces.

Additionally, cleaning of the equipment should be done only with a damp cloth.

7) Earthing

Bonding between conduit connections is not automatic and must be provided as part of the installation. Use of suitable grounding hubs and jumper wires are required.

The units are provided with internal and external earth terminals which are mounted in the base of the unit.

Internal earthing connections should be made to the Internal Earth terminal in the base of the housing using a ring crimp terminal to secure the earth conductor under the earth clamp. The earth conductor should be at least equal in size and rating to the incoming power conductors. When using the internal earth terminal ensure that the stainless steel M4 flat washer is between the incoming earth wire and the enclosure.

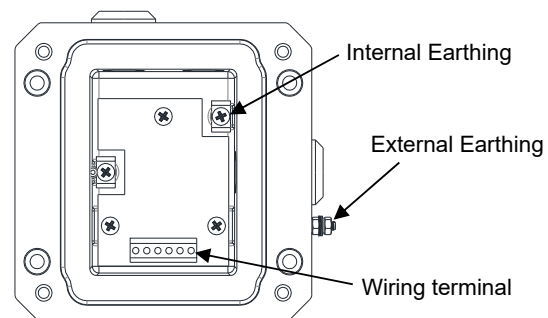

Fig 3 Earth terminals

8) Power Supply Selection

Electrical Ratings

250Vac max. / 3.3A max
48Vdc max. / 1.0A max
24Vdc max / 3.0A max

Electrical connections are to be made into the terminal blocks / DIN rail provided. See Section 11 for wiring options.

9) Selection of Cable, Cable Glands, Blanking Elements & Adapters

For high ambient temperatures the cable entry temperature may exceed +70°C or the cable branching point temperature may exceed 80°C and therefore suitable heat resisting cables and cable glands must be used, with a rated service temperature of at least the values stated below:

The cable gland entries have an M20 x 1.5 entry thread. Only suitably rated and ATEX / IECEx certified cable glands which must be suitable for the type of cable being used and also meet the requirements of the current Ex 'd' flameproof installation standards EN 60079-14 / IEC60079-14.

When only one cable entry is used the other entries must be closed with suitably rated and ATEX / IECEx certified blanking plugs.

If a high IP (Ingress Protection) rating is required then a suitable sealing washer must be fitted under the cable glands or blanking plugs.

The GNExCP7 Call Point range can be supplied with the following types of adapters:
M20 to 1/2" NPT
M20 to 3/4" NPT
M20 to M25

It is important to note that stopping plugs cannot be fitted onto adapters, only directly onto the M20 entries.

Any other adapters used must be suitably rated and ATEX / IECEx certified adapters.

10) Cable Connections

Electrical Connections are to be made into the terminal blocks using solid or stranded wire. See section 6 of this manual for access to the flameproof enclosure.

Wires having a cross sectional area between 0.5 mm² to 2.5mm² (AWG 20 – 14) can be connected to each terminal way.

If an input and output wire is required the 2-off Live/Neutral or +/- terminals can be used. If fitting 2-off wires to one terminal way the sum of the 2-off wires must be a maximum cross sectional area of 2.5mm².

Strip wires to 8mm. Wires may also be fitted using ferrules.

Terminal screws need to be tightened down with a tightening torque of:

DIN Rail Terminals: 0.51 Nm / 4.5 Lb-in;
Connector Block Terminals: 0.87 Nm / 7.7 Lb-in;

PCBA P1 Terminals: 0.45 Nm / 4.0 Lb-in;
PCBA EOL and Series (1 & 2) Terminals: 0.38 Nm / 3.4 Lb-in

When connecting wires to the terminals great care should be taken to dress the wires so that when the cover is inserted into the chamber the wires do not exert excess pressure on the terminal blocks. This is particularly important when using cables with large cross sectional areas such as 2.5mm².

11) Wiring Unit

The units come with two options for the terminal block. A DIN rail version which has 8-way connection and allows for limited wiring of EOL devices.

For Single Switch models GNExCP7-PT-S / GNExCP7-PM-S / GNExCP7-PB-S:

Max. ambient temperature (°C)	55	60	65	70
req. Cable/Cable Gland rating(°C):	80	85	90	95

For Dual Switch models GNExCP7-PT-D / GNExCP7-PM-D / GNExCP7-PB-D:

Max. ambient temperature (°C)	45	50	55	60	65	70
req. Cable/Cable Gland rating(°C):	80	85	90	95	100	105

The PCB Terminal Version has a 6-way connector but is designed to allow for full configuration with Series and EOL devices in a number of wiring configurations.

For EOL and Series device limitations and configurations see Section 13.

For wiring schematic see document D202-06-211

Wiring Diagram for 8-Way DIN Rail

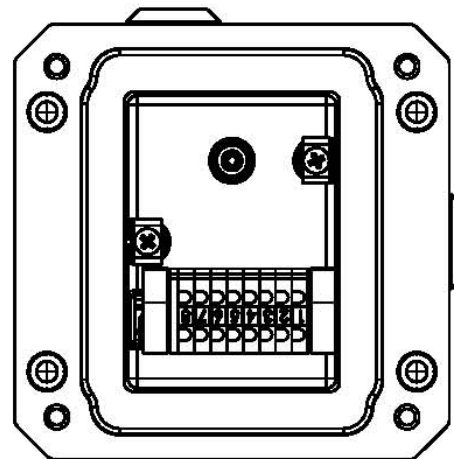

Fig. 4 DIN Rail in Base

Wiring Diagram for 6-Way PCB Terminal Board

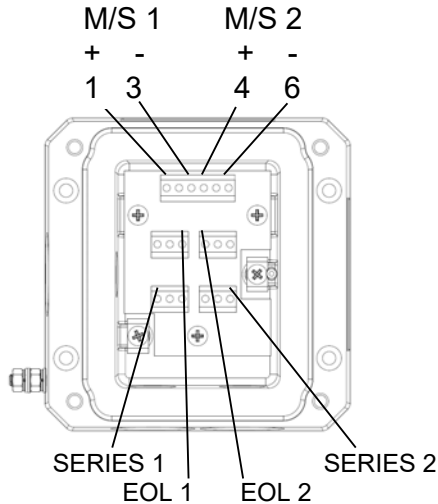

Fig. 5 PCB Terminal Block in Base

See section 13 and page 9 for details of adding Series and EOL devices on the PCB. This can either be done at the order stage or added to the correct terminal blocks afterward (see example on sheet 7). All devices must comply with the requirements stipulated in section 13.

12) Testing unit operation

The push button types -PB -PT and -PM are all operated by pressing in the main plunger down activating the switch.

PB – Dual Action Push Button

The -PB plunger needs to be firstly twisted by 90 degrees clockwise to position shown and then pressed in. There will be a click sound to indicate positive engagement and the plunger will stay in place.

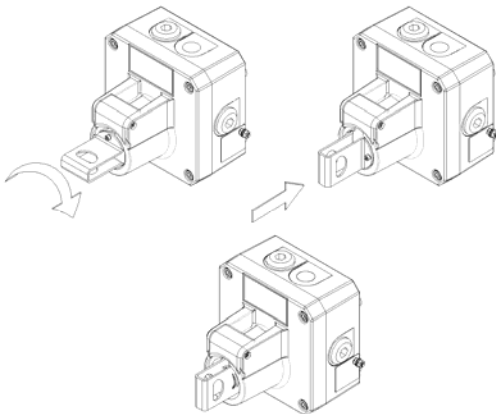

Fig 6 -PB Version Twist and Push Action

On -PB versions, the plunger will remain in position until the unit is reset. This is done by pulling the plunger back up to the start position shown in fig 6. Then the plunger is twisted back 90 degrees anti-clockwise to the stop.

PM – Momentary Push Button

The -PM needs to have the protective flip lid opened first and then the main plunger pressed in. There will be a click sound to indicate positive engagement, the plunger will spring back up if not held pressed.

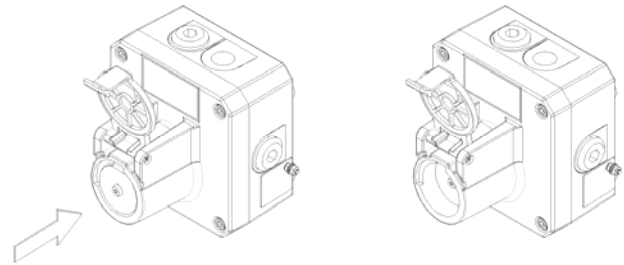

Fig 7 -PM Version Push Action

On -PM versions the operation is momentary and as such the plunger will reset automatically once the pressure on the plunger is released.

PT – Tool Reset Push Button

The -PT needs to have the protective flip lid opened first and then the main plunger pressed in. There will be a click sound to indicate positive engagement and the plunger will stay in place.

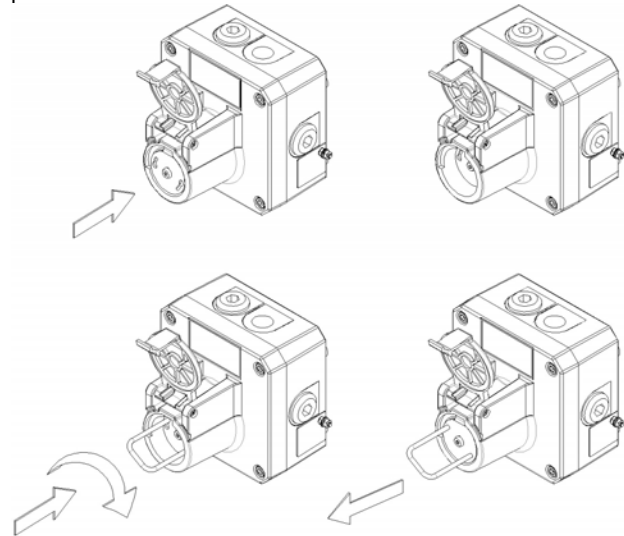

Fig 8a -PT Version Push Action

To reset, insert the reset tool supplied with the unit into the 2-off holes in the button plate, rotate clockwise along the curved slots and then pull the button plate back up. Rotate the tool anti clockwise and remove through the 2-off holes in the button plate.

13) End-of-Line and Series Devices

All models can be fitted with series resistors, end-of-line monitoring resistors, monitoring diodes and zener diodes if supplied with direct current up to 48Vdc and limited to a maximum total power consumption no greater than 6.224W.

Min. resistor values and current limitations must be observed depending on supply voltage and type of components fitted. If a combination of resistors / diodes / zener diodes is used, values for all components must be observed and lowest current limit for either component becomes overall limit.

Current limitation for units fitted with end-of-line resistors, diodes or zener diodes must be ensured by using a current limited power supply or fitting a current limiting resistor at the control panel (not provided).

The following table 1 shows limitations for all possible variations:

Type of component fitted	Supply voltage 24Vdc		Supply voltage 48Vdc	
	value	Max. current (mA)	value	Max. current (mA)
End-of-Line Resistor *See note	min. 470R/ 2W or min. 2k2/ 0.5W	3000	min. 2k2/ 2W or min. 8k2/ 0.5W	1000
End-of-Line Diode Type 1N5401	2W	59.13	2W	25.26
Series Resistor *See note	min. 470R/ 2W or min. 2k2/ 0.5W	3000	min. 2k2/ 2W or min. 8k2/ 0.5W	1000
Series Diode Type 1N5401	2W	59.13	2W	25.26
Series Zener Diode Type 1N5333B	3.3V	230	3.3V	230
	4.7V	162	4.7V	162
	5.1V	149	5.1V	149
	5.6V	136	5.6V	136
	6.2V	122	6.2V	122
	6.8V	112	6.8V	112
	10V	76	10V	76
	12V	63	12V	63

Note: - The maximum voltage stated must not be exceeded, as the internal resistor modules are rated as compliant with Ex d according to the unit voltage.

If lower value resistors than seen on table are required it may be possible to configure but seek advice from E2S to ensure compliance is still maintained.

EOL (End of line) device;

- resistor – ExxxR
- diode – ED1
- zener – ExxxZ

Series (In line) device;

- resistor – SxxxR
- diode – SD1
- zener – SxxxZ
- LED

Microswitch 1 = M/S 1

Microswitch 2 = M/S 2

The unit can be wired with a maximum of 4 module devices – see wiring schematic D202-06-211

When customer is fitting EOL or Series devices, ensure device leads are insulated or routed so as not to create an electrical short.

14) Maintenance, Overhaul & Repair

Maintenance, repair and overhaul of the equipment should only be carried out by suitably qualified personnel in accordance with the current relevant standards:

EN60079-19/IEC60079-19 Explosive atmospheres - Equipment repair, overhaul and reclamation

EN60079-17/IEC60079-17 Explosive atmospheres - Electrical installations inspection and maintenance

To avoid a possible ELECTROSTATIC CHARGE the unit must only be cleaned with a damp cloth.

Units must not be opened while an explosive atmosphere is present.