

BExCP3B-BG, BExCP3D-BG & BExCP3E-BG Manual Call Point – Break Glass With Resistor Modules For use in Flammable Gas and Combustible Dust Atmospheres.

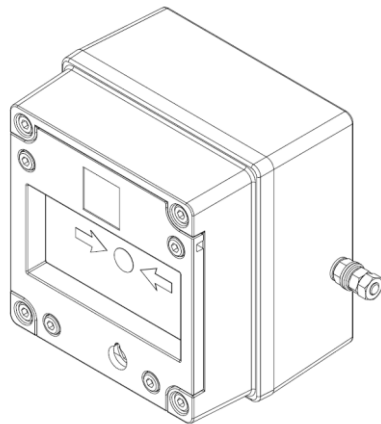

1) Introduction

The BExCP3B-BG / BExCP3D-BG / BExCP3E-BG is a break glass manual call point which is certified to the European and International Gas and Dust standards. The unit meets the requirements of the ATEX directive 2014/34/EU and IECEx scheme.

The call point can be used in hazardous areas where potentially flammable gas and dust atmospheres may be present.

All units have up to two of the following series and/or EOL devices:

- Monitoring resistors per module: -
 - BExCP3B-BG - 2.0W Max
 - BExCP3D-BG - 1.0W Max
 - BExCP3E-BG - 1.75W Max
- Monitoring diode
- Monitoring Zener diode

The units are Group II, EPL (equipment protection level) Gb. The equipment is certified 'Ex db eb mb IIC T4 Gb' and as such may be used in Zones 1 and 2 with flammable gases and vapours with gas

groups IIA, IIB & IIC and temperature classes T1, T2, T3 and T4.

These units are also Group III, EPL Db. The equipment is certified

'Ex tb IIC T60°C Db' (BExCP3B-BG),
'Ex tb IIC T80°C Db' (BExCP3D-BG),
'Ex tb IIC T75°C Db' (BExCP3E-BG)
and as such may be used in Zones 21 and 22 for combustible dusts groups IIIA, IIIB & IIIC.

2) Ratings & Markings

All units have a rating label, which carries the following important information: -

Unit Type No.:
BExCP3B-BG Manual Call Point
BExCP3D-BG Manual Call Point
BExCP3E-BG Manual Call Point

Input Voltages
48VDC nominal 56VDC Max 0.75A Max
24VDC nominal 28VDC Max 5.0A Max Resistive Load; 3.0A Max Inductive Load
12VDC nominal 15VDC Max 5.0A Max
6VDC nominal 9VDC Max 5.0A Max

Code:
BExCP3B-BG
Ex db eb mb IIC T4 Gb
Ex tb IIC T60°C Db
IP66
-40°C ≤ Ta ≤ +50°C

BExCP3D-BG	BExCP3E-BG
Ex db eb mb IIC T4 Gb	Ex db eb mb IIC T4 Gb
Ex tb IIC T80°C Db	Ex tb IIC T75°C Db
IP66	IP66
-40°C ≤ Ta ≤ +70°C	-40°C ≤ Ta ≤ +65°C

Certificate No.:
SIRA 09ATEX3286X
IECEx SIR 09.0121X

Epsilon x:  II 2GD

CE Marking  2813
Notified body No.

Year/Serial No. i.e. 20/1CP3BBG000001
Or 20/1CP3DBG000001
Or 20/1CP3EBG000001

**WARNING - DO NOT OPEN WHEN AN
EXPLOSIVE ATMOSPHERE MAY BE PRESENT**

3) Type Approval Standards

The call point has an EC Type examination certificate issued by SIRA and have been approved to the following standards: -

EN60079-0:2018 / IEC60079-0:2017
EN60079-1:2014 / IEC60079-1:2014
EN60079-7:2015 / IEC60079-7:2017
EN60079-18:2015 / IEC60079-18:2014
EN60079-31:2014 / IEC60079-31:2013

The equipment is certified for use in ambient temperatures in the range
BExCP3B-BG -40°C to +50°C
BExCP3D-BG -40°C to +70°C
BExCP3E-BG -40°C to +65°C

and shall not be used outside this range.

4) Installation Requirements

Installation of this equipment shall only be carried out by suitably trained personnel in accordance with the applicable code of practice e.g. IEC 60079-14/EN 60079-14

Repair of this equipment shall only be carried out by the manufacturer or in accordance with the applicable code of practice e.g. IEC 60079-19/EN 60079-19.

Refer to certificates SIRA 09ATEX3286X and IECEx SIR 09.0121X for special conditions of safe use.

The certification of this equipment relies on the following materials used in its construction:

Enclosure: Aluminium Pressure Die Cast Body LM6

Through enclosure mechanism: Plastic Nylon Zytel Injection Moulded

Sealing of enclosure and mechanism: O-ring Acrylonitrile-Butadiene Rubber

Potting Compound of resistors where used: Epoxy Resin

If the equipment is likely to come into contact with aggressive substances, then it is the responsibility of the user to take suitable precautions that prevent it from being adversely affected, thus ensuring that the type of protection is not compromised.

"Aggressive substances" - e.g. acidic liquids or gases that may attack metals, or solvents that may affect polymeric materials.

"Suitable precautions" - e.g. regular checks as part of routine inspections or establishing from the material's data sheet that it is resistant to specific chemicals.

5) Call Point Location and Mounting

The location of the call point should enable ease of access for operation and testing. The unit should be mounted using the 4 off fixing holes which will accept up to M4 sized fixings.

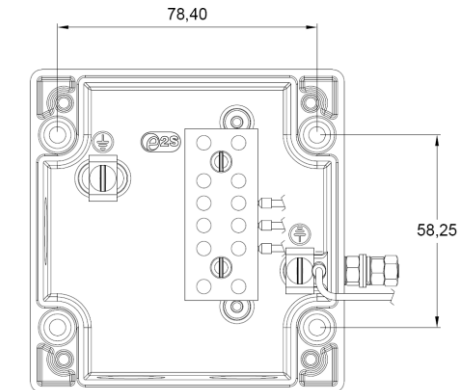

View of base unit showing fixing centers.

To gain access to the mounting holes in the base the front cover must be removed. This is achieved by removing the 4 off M4 cap head bolts holding on the cover.

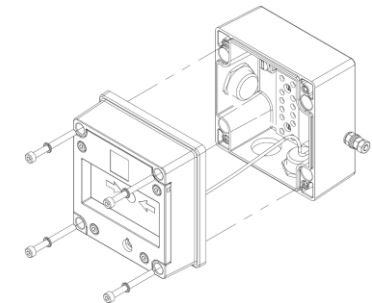

Once the screws are removed the cover will hang down out of the way to gain access to the Ex e terminal block, the internal earth terminal and mounting hole recesses.

6) Earthing

The unit has both internal and external earth terminals.

It is recommended that a cable crimp lug is used on the earth wires.

The internal earth wire is placed under a earth clamp which will stop the cable twisting. This is secured by an M4 screw and spring washer.

The external earth lug should be located between the two M5 washers provided and securely locked down with the M5 spring washer and two locknuts.

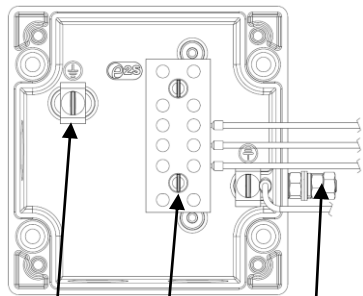

Internal Earth terminal
Ex e terminal block
External Earth Stud

Note: Depending on options chosen an 8-Way DIN Rail or 6-Way terminal block may be selected.

7) Cable connections

There are 3 off cable entry holes suitable for M20x1.5 Ex e approved cable glands or stopping plugs

The unit can be wired in a number of different ways depending on the resistor combination selected. For detail, refer to wiring schematic D150-06-051.

EOL (End of line) device;
resistor – ExxxR / diode – ED1 / zener – ExxxZ
Series (In line) device;
resistor – SxxxR / diode – SD1 / zener – SxxxZ
Microswitch 1 = M/S 1

Voltage option	Max Voltage	Min resistor value allowable in module Type B unit (2.0W)	Min resistor value allowable in module Type D unit (1.0W)	Min resistor value allowable in module Type E unit (1.75W)
6 V dc	9 V dc	47 ohms	91 ohms	51 ohms
12V dc	15 V dc	120 ohms	240 ohms	150 ohms
24V dc	28 V dc	470 ohms	820 ohms	510 ohms
48V dc	56 V dc	1K8 ohms	3K3 ohms	2K0 ohms

When wiring to Increased Safety terminal enclosures, you are only permitted to connect one wire into each way on the terminal block, unless a pair of wires are crimped into a suitable ferrule. For the six-way terminal block wire sizes allowable are 0.5mm² to 4.0mm². For the 8-way DIN rail wire sizes allowable are 0.5mm² to 2.5mm².

Leads connected to the terminals shall be insulated for the appropriate voltage and this insulation shall extend to within 1mm of the metal of the terminal throat. They shall only be installed and wired with cable in an ambient temperature of -10°C to +80°C

All terminal screws, used or unused, shall be tightened down to between 0.5 Nm and 0.7 Nm

7.1) Fitted LED, Diode or Zener Diode

If a diode module is pre-fitted as either an EOL or series device, the following current limitation applies:

Voltage	Max. Current
48V DC	0.75A
6, 12 & 24V DC	2.0A

If a Zener diode module is pre-fitted as either EOL or Series device, the following current limitation applies:

Zener Voltage	Max. Input Voltage	Max. Current
3.3V	56V DC	230mA
4.7V		162mA
5.1V		149mA
5.6V		136mA
6.2V		122mA
6.8V		112mA
10V		76mA
12V		63mA

In any scenario, the lowest value of maximum current should be used. For example, if the unit has both a diode and a Zener diode, the Zener diode would determine the maximum input current of the unit, since its max. current is lowest.

8) Testing unit operation

The break Glass unit can be tested without the need to break/replace the frangible glass element. A test key is used to mechanically drop the glass down activating the switch.

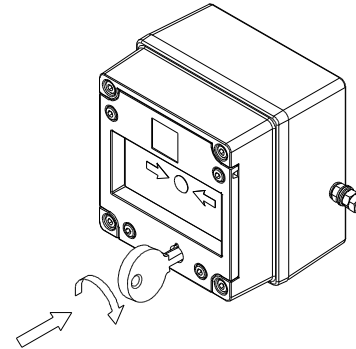

The test key is inserted in the test cam and rotated clockwise by an angle of 60° the glass element will visibly drop down in the viewable window.

The call point switch will now change over its contacts to operate the alarm. Once testing is complete the unit needs to be reset, the test key is rotated back anticlockwise by an angle of 60° back to its original position. The glass element should now raise up so it is level again in the viewable window.

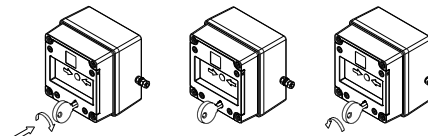

1. Insert test Key rotate clockwise 60°
2. Hold in position during test
3. Rotate back anticlockwise to reset

9) Replacement of glass element

If the break glass unit has been operated the broken glass element can be quickly replaced. The break glass cover plate is removed by unscrewing the 4 off M4 cap head screws attaching it.

Once cover is removed the broken glass will be free to be removed, clean out any other fragments of glass carefully.

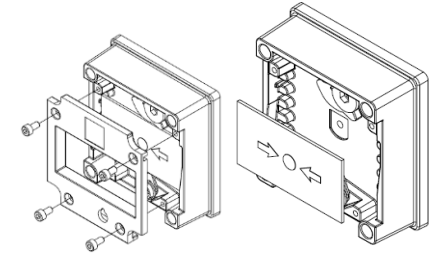

To fit the new glass element rotate the top cam clockwise by an angle of 50° (use a 6mm Allen key) this will then allow the glass to fit back into the pocket it sits in, resting on the pivot point and test cam, release the top cam to rest on the top of the glass element.

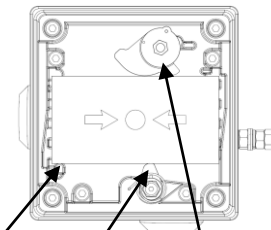

Pivot point Test Cam Top Cam (rotate)

Replace the cover plate and tighten the 4 off M4 cap head screws.

Ensure the glass element is free to move under the cover plate. This can be done by running through the units test operation. See section 8 of this instruction manual.

10) SIL 2 Reliability Data

Reliability and Functional safety IEC/EN61508 which has been assessed and is considered suitable for use in low demand safety function:

- Random Hardware Failures and Systematic Failures (route 2H)
- As an unvoted item (i.e. hardware fault tolerance of 0) at SIL 2

The product was assessed against failure modes:

- Failure to close a contact when the call point is struck with specified force
- Failure to open a contact when the call point is struck with specified force
- Spurious output despite no input

Integrity in respect of failure to close	SIL 2
Total Failure rate	0.133 pmh
"hazardous" failure rate (revealed)	0 pmh
"hazardous" failure rate (unrevealed)	0.1 pmh
"safe" failure rate (revealed)	0.033 pmh
"safe" failure rate (unrevealed)	0
Diagnostic Coverage	99%
System type	A
Hardware Fault Tolerance	0
Safe Failure Fraction	>99%
PFD (hazardous failure)	1.25×10^{-3}
Proof Test Interval	Up to 1 year