

BExTS110 Explosion Proof Telephone Initiated Alarm Horn

The flameproof BExTS110 telephone initiated sounders are suitable for Zone 1, 2, 21 & 22 applications. Approved to IECEx, ATEX, Ex EAC and INMETRO standards.

Sound level outputs are up to 117dB(A) at 1 metre with a choice of 32 alarm tones. The ring-tone circuit senses the ringing voltage on the telephone line and switches the supply onto signal until the telephone is answered. The sound can be continuous or it can follow the telephone ring (selectable option). The BEx range features enclosures manufactured from corrosion proof, marine grade copper free LM6 aluminium with chromate and powder coat finish.

Features

- Marine grade, corrosion proof, LM6 aluminium enclosure.
- Ingress protection IP66/67
- Stainless steel fixings
- Dual M20 cable entries – adaptors available.
- Stopping plug included.
- Very large termination area.
- Ratchet adjustable stainless steel 'U' bracket.
- Telephone line ringing voltage switches power (115vac or 230vac) to enable sounder to operate.

Approvals

- IECEx KEM 10.0003X
- ATEX KEMA 99ATEX6312X
- TR-CU Ex EAC certificate: RU C-GB.AA71.B.00109
- INMETRO certificate: 10IEx-0009

Coding

- II 2G Ex db IIB T4 Ta -50° to +70°C
- II 2G Ex db IIC T4 Ta -50° to +55°C
- II 2D Ex tb IIIC T100°C Db Ta -50°C to +55°C
- II 2D Ex tb IIIC T115°C Db Ta -50°C to +70°C



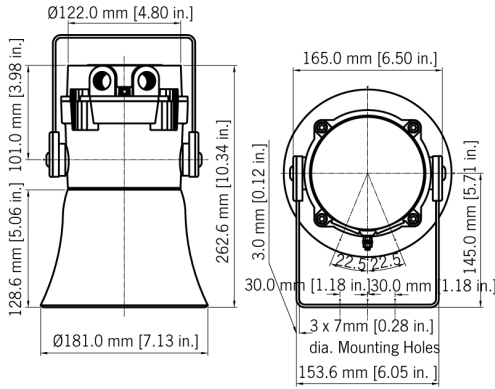

Specification

| | |
|---|--|
| Maximum output: | 117dB(A) @ 1 metre [108dB(A) @ 10ft/3m] |
| Nominal output: | 110dB(A) @ 1m +/- 3dB - Tone 2 [101dB(A) @ 10ft/3m] |
| No. of tones: | 32 (UK00A / PFEER compliant) |
| Effective range: | 100m/328ft @ 1KHz |
| Voltages AC: | 115vac; 230vac |
| Ingress protection: | IP66/67 |
| Enclosure matl: | Marine grade copper free LM6 Aluminium |
| Enclosure finish: | Chromate & powder coated finish - anti-corrosion. |
| Colour: | RAL3000 Red Grey RAL7038 Special - available on request |
| BExTS110 flare: | High impact UL94 V0 & 5VA FR ABS |
| Cable entries: | Dual M20 ISO (one stopping plug inc) |
| Terminals: | 0.5 - 2.5mm ² (20-14 AWG) |
| Enclosure volume: | <2 litres |
| Relative humidity: | 95% - Additional tropicalisation is recommended for applications where both high relative humidity and high ambient temperatures exist |
| Weight : | 3.20kg/7.04lbs |
| *SPL data +/-3dB(A). Measured at optimum voltage. | |

Part Codes

| | | |
|----------------------|-------------------|---|
| Version: | Part code: | |
| Product type: | BExTS110 | Explosion proof Telephone Initiated Alarm |
| Type: | DF | Ex d, Flare re-entrant horn |
| Voltage: | AC115 | 115V ac |
| | AC230 | 240V ac |
| Cable Entry Type: | A | 2 x M20x1.5mm |
| [e] | B | 2 x 1/2" NPT - adaptors |
| | C | 2 x 3/4" NPT - adaptors |
| | D | 2 x M25x1.5mm - adaptors |
| | E | 1 x 1/2" NPT - adaptor |
| | F | 1 x 3/4" NPT - adaptor |
| | G | 1 x M25x1.5mm - adaptor |
| Adaptor/Stopping | B | Brass |
| plug material: [m] | N | Nickel Plated |
| | S | Stainless Steel |
| Bracket matl & tag: | 1 | A2 304 Stainless Steel |
| [s] | 2 | A4 316 Stainless Steel |
| | 3 | A2 304 St/St with Equip. Tag |
| | 4 | A4 316 St/St with Equip. Tag |
| Product version: [v] | A1 | Default - IECEx, ATEX, Ex EAC & INMETRO |
| Enclosure colour: | R | Red RAL3000 |
| [x] | G | Grey RAL7038 |
| | S | Special - contact E2S |
| Accessories: | SP65-0001-A2 | Pole Mount Bracket Kit 2" St/St A2 (304) |
| | SP65-0001-A4 | Pole Mount Bracket Kit 2" St/St A4 (316) |
| | SP65-0003-A2 | Sunshade - St/St A2 (304) |
| | SP65-0003-A4 | Sunshade - St/St A4 (316) |

Current Consumption

| | | | |
|-----------------|-----------|-----------------|-----------------|
| Version: | | Voltage: | Current: |
| 115V ac | 50Hz/60Hz | +/-10% | 110mA |
| 230V ac | 50Hz/60Hz | +/-10% | 56mA |

Tone table

S 1 Description

| | |
|------|--|
| T 1 | Continuous 1000Hz Toxic Gas Alarm |
| T 2 | Alternating 800/1000Hz at 0.25s intervals |
| T 3 | Slow Whoop 500/1200Hz at 0.3Hz with 0.5s gap ... |
| T 4 | Sweeping 800/1000 at 1Hz |
| T 5 | Continuous at 2400Hz |
| T 6 | Sweeping 2400/2900Hz at 7Hz |
| T 7 | Sweeping 2400/2900Hz at 1Hz |
| T 8 | Siren 500/1200/500Hz at 0.3Hz |
| T 9 | Sawtooth 1200/500Hz at 1Hz |
| T 10 | Alternating 2400/2900Hz at 2Hz |
| T 11 | Intermittent 1000Hz at 0.5Hz General alarm |
| T 12 | Alternating 800/1000Hz at 0.875Hz |
| T 13 | Intermittent 2400Hz at 1Hz |
| T 14 | Intermittent 800Hz 0.25s on 1s off |
| T 15 | Continuous at 800Hz |
| T 16 | Intermittent 660Hz 150mS on, 150mS off |
| T 17 | Alternating 544Hz (100mS)/440Hz(400mS) |
| T 18 | Intermittent 660Hz 1.8s on, 1.8s off |
| T 19 | 1400Hz to 1600Hz sweep up over 1s -1600Hz to ... |
| T 20 | Continuous 660Hz |
| T 21 | Alternating 554/440Hz at 1Hz |
| T 22 | Intermittent 554Hz at 0.875Hz |
| T 23 | 800Hz pulsing at 2Hz |
| T 24 | Sweeping 800/1000Hz at 50Hz |
| T 25 | Sweeping 2400/2900Hz at 50Hz |
| T 26 | Simulated bell sound |
| T 27 | Continuous 554Hz |
| T 28 | Continuous 440Hz |
| T 29 | Sweeping 800/1000Hz at 7Hz |
| T 30 | 420Hz repeating 0.625s on, 0.625s off Austral... |
| T 31 | 1200/500Hz at 1 Hz Prepare to Abandon Platform |
| T 32 | Sweeping 500/1200Hz 3.75s on, 0.25s off 15Hz |